



INLINE QUALITY INSPECTION IN BATTERY PRODUCTION

From web-based production processes
to the end of line battery cell inspection

ISRA
VISION
Part of Atlas Copco Group

INLINE QUALITY INSPECTION IN BATTERY PRODUCTION

ISRA VISION is your trusted partner for inline quality inspection solutions in battery production. As a globally active machine vision company, we focus on providing customized solutions with modern high-performance cameras, lighting systems tailored to the respective application and intelligent software solutions and algorithms. Our experience in a wide range of industrial segments gives us comprehensive expertise in this context.

Quality monitoring of the battery production process is essential to ensure an efficient, economical, and sustainable production. Using inline quality inspection systems at every stage of manufacturing provides operators and engineers with valuable insights into product quality, enabling them to optimize the process and achieve the highest standards.

THE STRENGTH OF ISRA VISION

- In-house production of high-performance cameras
- Intelligent illumination solutions
- Sophisticated & application-oriented software feature

SOLUTIONS FOR

- Web-based production processes: separator film, electrode film
- Cell inspection: End-of-line inspection for prismatic, cylindrical and pouch cells

ISRA
VISION

WEB INSPECTION

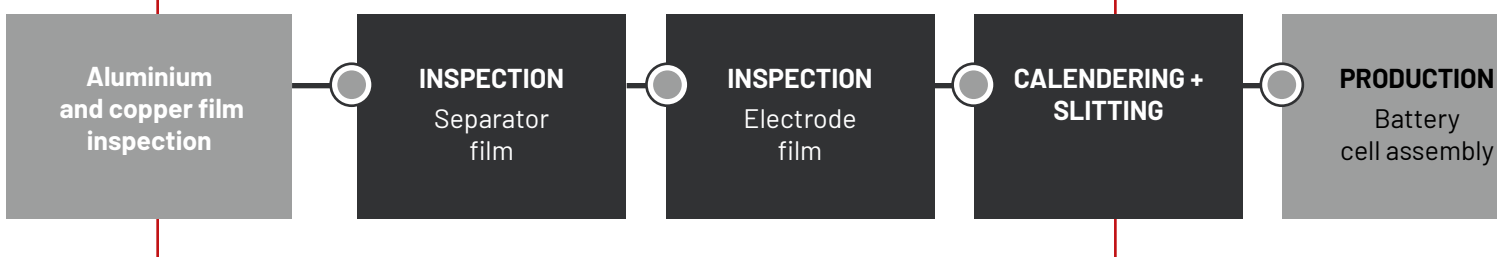



- 100% inline inspection to control the entire web
 - 100% inline tested battery cells
 - Reduced operating costs thanks to optimized production processes
 - Maximum product safety to avoid recalls and incidents
- Saving of raw materials and energy along the value chain

WE SUPPORT YOU

- Consulting
- Training
- Data driven service
- Service level agreements
- Installation
- Field service
- Spare parts

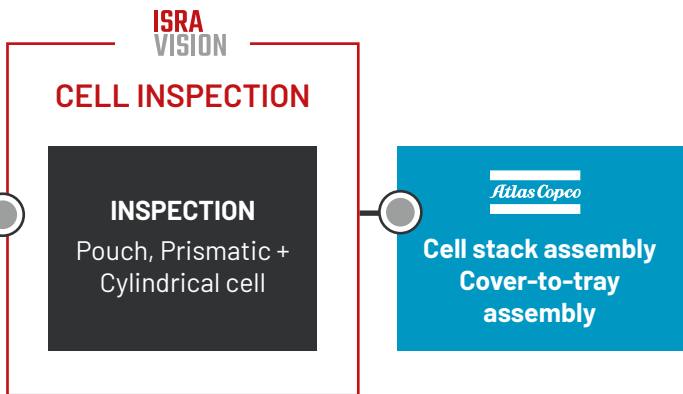
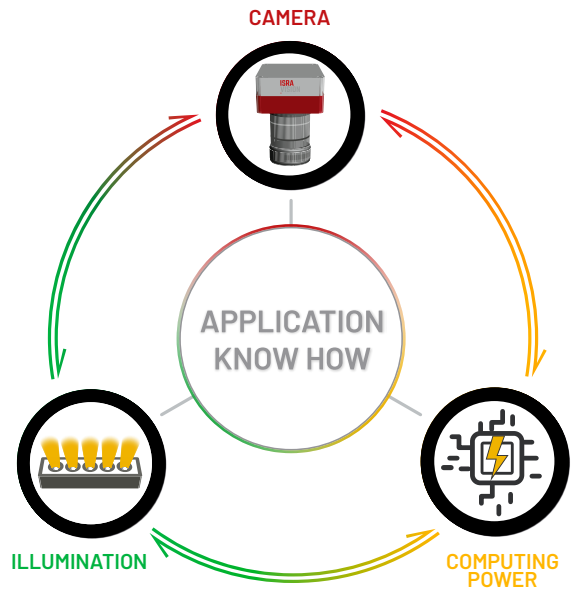

INLINE QUALITY INSPECTION OF THE SEPARATOR FILM

In battery production, a high level of precision is required when processing material webs in order to guarantee a safe and high-quality product. To achieve this, manufacturing companies need a suitable basis for decision-making along with accurate data to optimize production and reduce waste.

Separator film inspection

Separator film is a component of the lithium-ion battery. This membrane separates the anode from the cathode and thus enables the safe and functional exchange of lithium ions. The separator is also an essential safety element to prevent a short circuit in the battery and increase the service life of the cells.

After extrusion, stretching, and coating, the highly treated separator film must be carefully inspected to ensure 100% product quality and safety. This ensures no defects are present at an early stage in the battery manufacturing process.

Here are the benefits of using our separator film inspection solution:

Reliable defect classification through the use of HDR technology

- Differentiation between pin holes and thin spots

Inspection and documentation of the separator film over the entire length and width of the web

- Flawless material
- Avoidance of critical defects
- Increase in productivity

Holistic solution approach for process optimization

- From defect data to decision data
- Live and analytical dashboards (in-house development)
- Enabler on the path to Industry 4.0

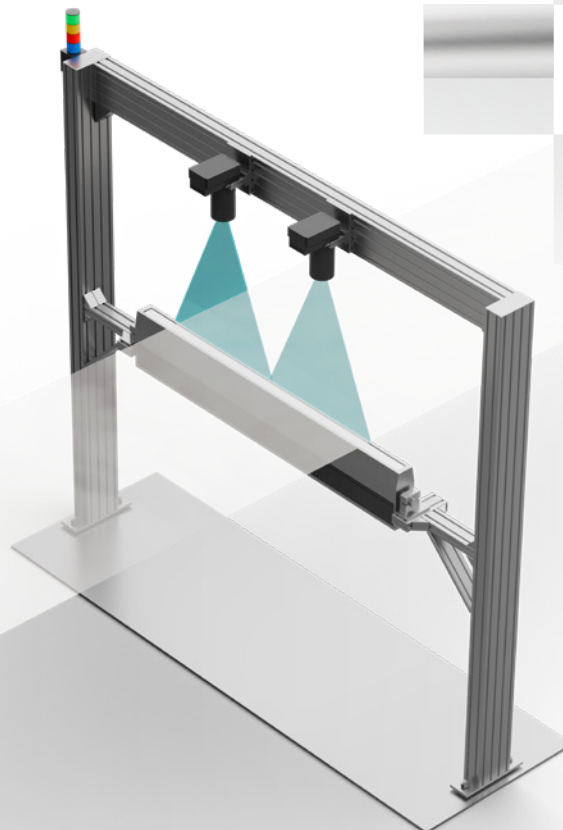



Typical defects

- Black spots
- Coating defects
- Holes
- Large scratches
- Metal particles
- Oil drips
- Repetition error
- Slitting defects
- Thin spots
- Water droplets

Technical data

- Line speed: 120 - 400 m/min.
- Line width: up to 7800 mm
- Main Line, Coating/Slitting Line: up to 1700 mm
- System resolution: 20 - 100 μ m

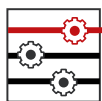

Tailored to your specific production requirements

Highest reliability for hole classification

- Max security: Sensitive hole detection with Real-time MultiScan (HDR) inspection
- Max yield: Reliable thin spot vs. hole classification with HDR inspection

Highest reliability for hole classification

Low intensity

High intensity

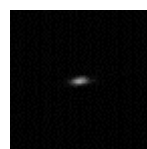

Thin spot

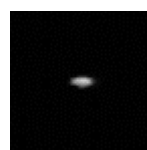
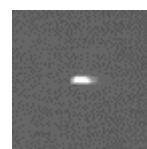

Thin spot

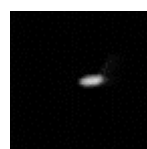
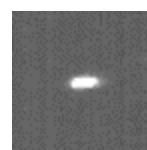

Hole

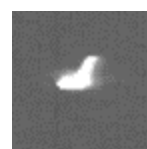

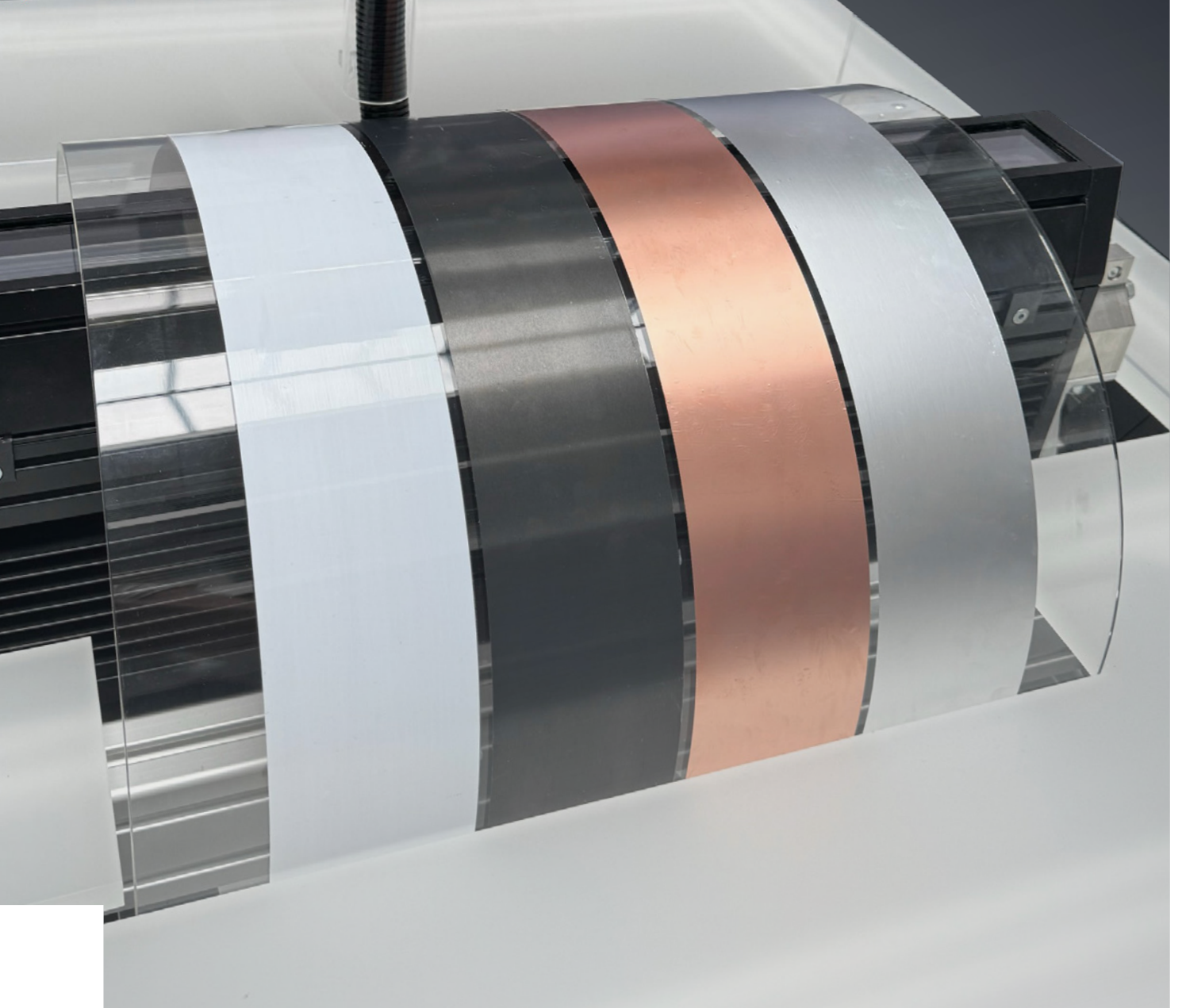

INLINE QUALITY INSPECTION OF THE ELECTRODE FILM

Meet the high-quality requirements for electrode film throughout the entire production process.

High-performance battery electrodes are crucial components of battery cells. Coated electrode foils for both cathodes and anodes must meet stringent production and inspection standards. The quality of these electrodes directly impacts the performance and safety of each battery cell.



Coating

Our inline quality inspection system is vital for verifying adherence to the following criteria: flawless coatings (defect detection + classification), measuring the geometric positions of front and rear sides (measurement), providing accurate quality and measurement data in real-time. Track all quality data along the process-chain (Track & Trace). Communication with other devices (for example for web guidance or 3D measurement)

DEFECT DETECTION
+ CLASSIFICATION

MEASUREMENT

TRACK & TRACE

INTERFACES



Calendering

After the demanding process of the roller press, the Aluminium and copper-coated electrode foils are subjected to another precise quality inspection. The aim is to achieve a fully homogeneous coating and 100% geometric monitoring.



Slitting

During the cutting process, reliable data transfer from the parent roll to the child roll must be ensured. In addition, geometric monitoring of the coated electrode foils is crucial.

Technical data

- Line speed: 120 - 400 m/min.
- Line width:
- Main lines: 4500 - 7800 mm
Coating/Slitting: 1200 - 1700 mm
- System resolution: 20 - 100 μm

Typical defects

- Agglomerate
- Contamination
- Micro-compression
- Mud Crack
- Pinhole
- Slip
- Stripe

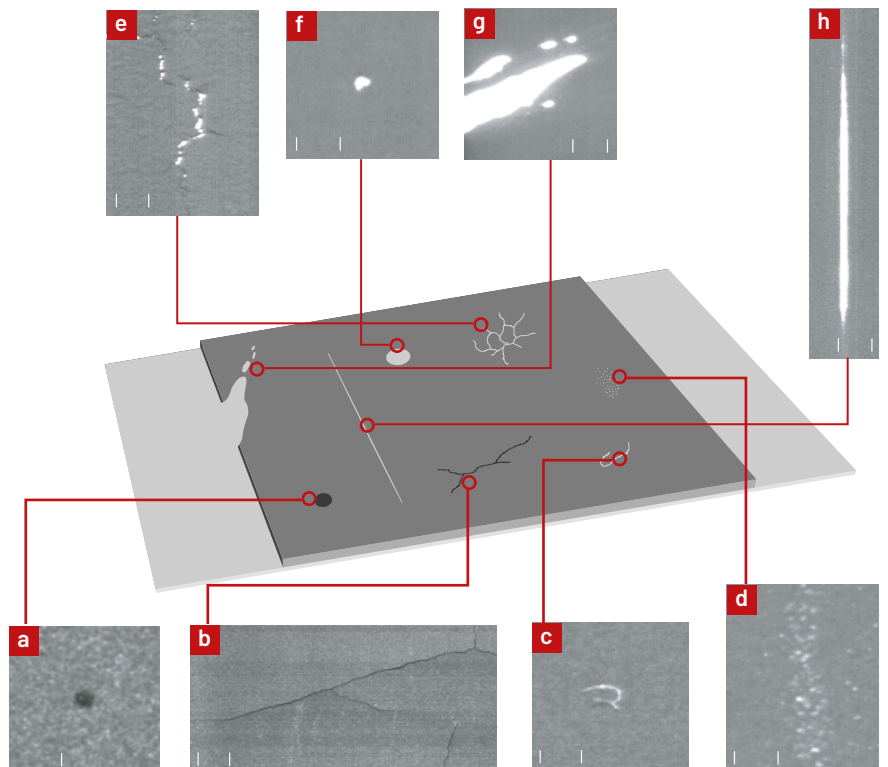

MEASUREMENT AND WIDTH MONITORING

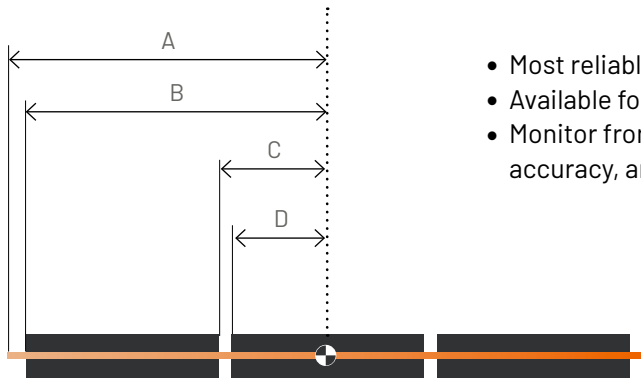

- Most reliable edge detection and advanced edge quality analysis
- Available for different coating types
- Monitor front and rear alignment to minimize waste, enhance accuracy, and optimize yield.

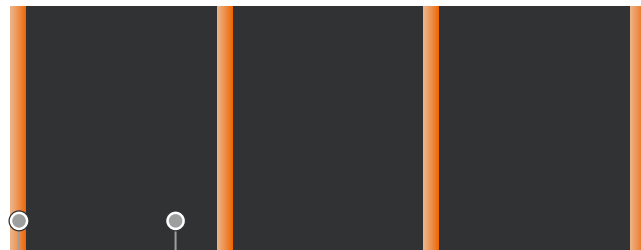

Aluminium /
Copper film Coating

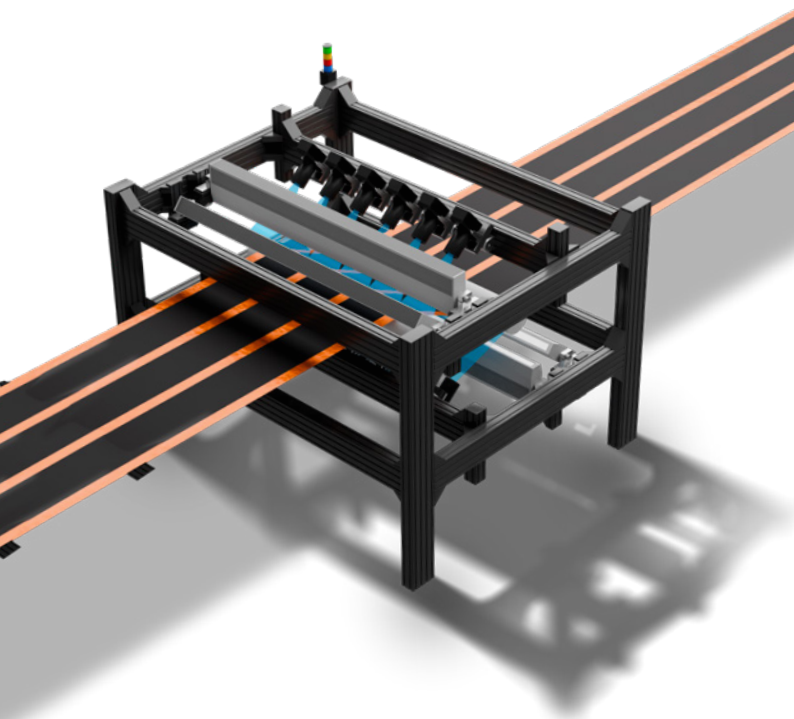

Here are your benefits from using our electrode coating inspection solution at a glance:

Reliable defect classification

- Use of multiple lighting channels
- Self-learning classifier (AI + deep learning)
- Use of HDR technology

Inspection and documentation of the electrode film over the entire length and width of the web

- All-in-one high-speed camera (400 KHz) or CIS-Sensor with 600 or 1200dpi with highly optimized LED lighting
- Avoidance of critical errors
- Monitoring of error patterns and geometric deviations

Holistic solution approach for process optimization

- From defect data to decision data
- Live and analytical dashboards (in-house development)
- Implementation of track and trace strategies



- Making an active contribution to sustainability goals
- Minimizing waste, reducing raw material and energy consumption

Learn more:



PRODUCTION ANALYTICS

One Solution for All Data Driven Applications

With the EPROMI production analysis software, ISRA VISION offers a software platform that allows you to check the system status of all production lines at a glance or analyze production data in detail. With the quality management system, you can analyze historical data, monitor current inspection data in real time and identify future trends in your production process.

Dashboards allow you to compare production line and product data onsite or remotely, providing key insights for optimization. This enables you to make informed professional decisions along your value chain to increase the product quality as well as profitability. You can continuously track the progress of optimization measures and present them with visualized advanced reports.

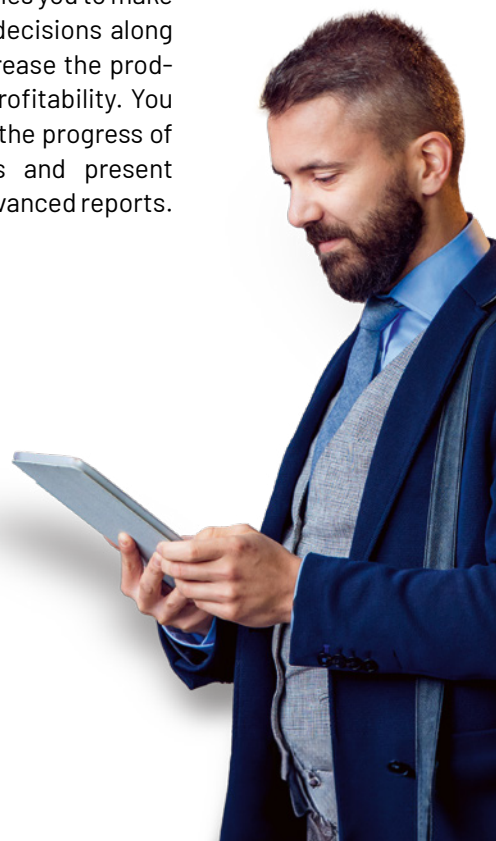

END OF LINE BATTERY CELL INSPECTION

The rapid pace of innovation in battery applications must not compromise quality. Thus, integrating a cell inspection system is essential for the battery production process.

The inspection system can be integrated directly into the production line and enables 360° inspection of cylindrical, prismatic and pouch cells. It is typically used before or after the formation and aging process. It detects 2D and 3D surface defects such as dents, dings, scratches, wrinkles, and contamination, for example from electrolytes. The inspection system reliably detects and classifies critical defects on the surface and edge areas and monitors the dimensions and sealing seams of the cells.

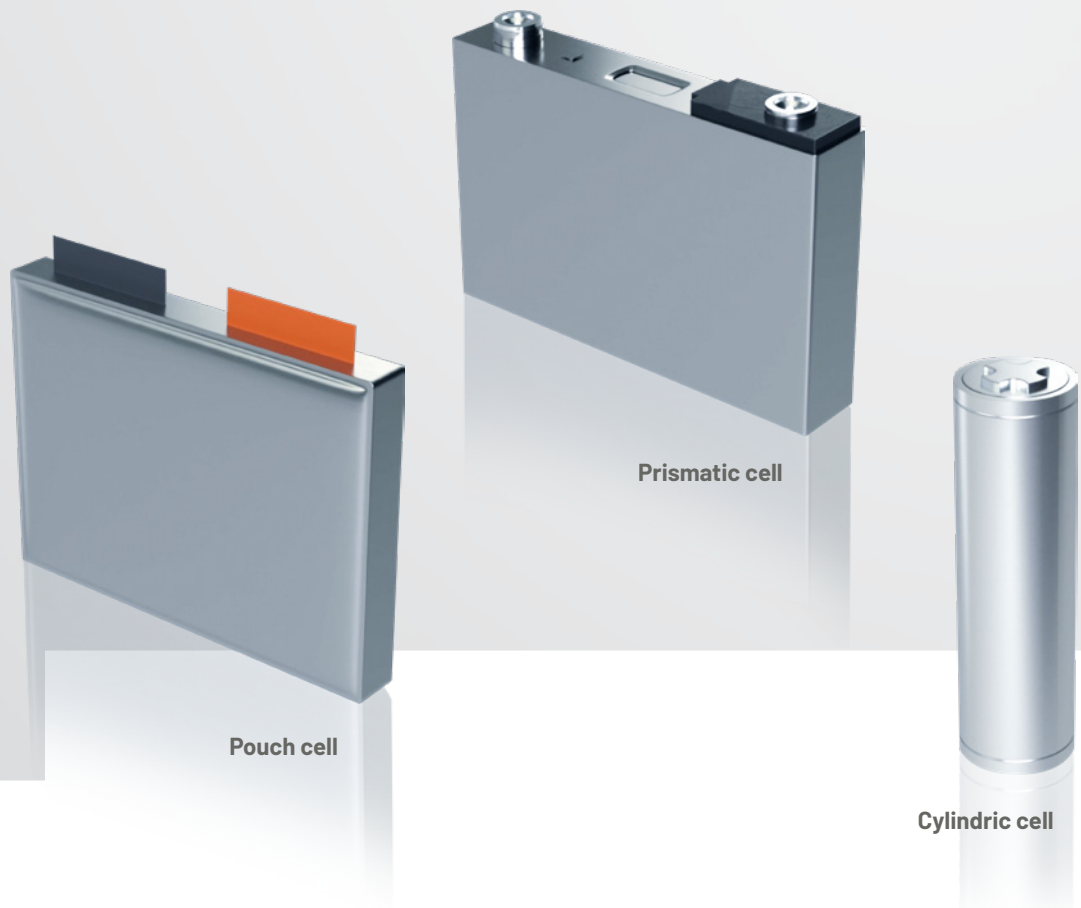

Inline inspection of battery cells during ongoing production:

- Inspection of all surfaces including the critical edge areas
- Battery format-specific image processing set-up for inline inspection (cycle time 15 ppm and more)

Reliable defect classification:

- AI-supported anomaly detection of the critical edge areas
- Detection of 2D and 3D defects
- Monitoring of geometric dimensions

Holistic solution approach for process optimization :

- From defect data to decision data
- Live and analytical dashboards (in-house development)
- Implementation of track and trace strategies

Pouch cell inspection

- Contamination/foreign objects
- Defects in the seal
- Dents
- Edge cracks
- Folding errors
- Scratches
- Unevenness

Technical data

- Cycle rate: approx. 15ppm
- Required cycle time: 4 sec.
- Target defect size: > 50µm

Prismatic cell inspection

- Dent
- Edge cracks
- Electrolyte residues
- Foreign objects
- Holes / pinholes
- Micro scratches
- Scratches
- Wrinkles

Technical data

- Cycle rate: approx. 20ppm
- Required cycle time: 3 sec.
- Target defect size: > 50µm

Cylindrical cell inspection

- Burrs
- Dents and dings
- Deviations from the geometry
- Edge deformation and other
- Electrolyte residues
- Rust and other residues
- Scratches

Technical data

- Cycle rate: Limited by mechanical transport
- Required reaction time: approx. 3 seconds
- Target defect size: 50µm

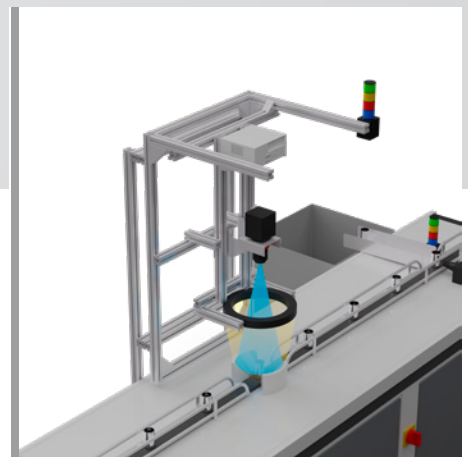
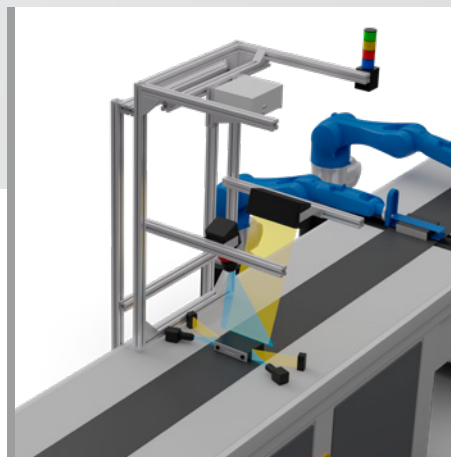
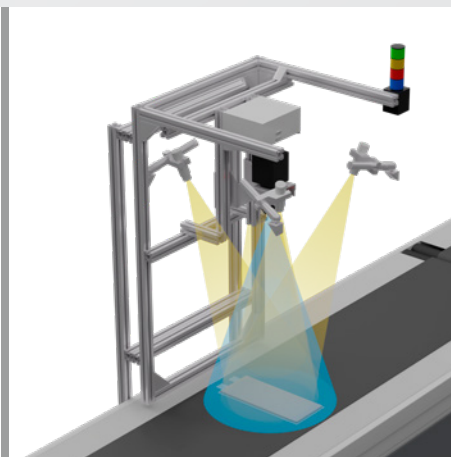

100% inline inspection to control the entire web



100% inline tested battery cells



Reduced operating costs thanks to optimized production processes



Maximum product safety to avoid recalls and incidents



Saving of raw materials and energy along the value chain

